

SANUS®

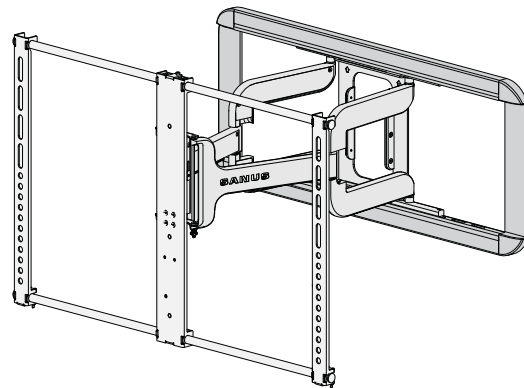

VLF320 INSTRUCTION MANUAL

We'll Make It Stress-Free

If you have any questions along the way, just give us a call.
1-800-359-5520 (UK: 0800-056-2853) We're ready to help!

Scan for easy install video

<http://san.us/725>



IMPORTANT SAFETY INSTRUCTIONS – SAVE THESE INSTRUCTIONS – PLEASE READ ENTIRE MANUAL PRIOR TO USE

Before getting started, let's make sure this mount is perfect for you!

1 Does your TV weigh *more* than 120 lb (54 kg) including accessories?



No — Perfect!

Yes — This mount is NOT compatible. Visit MountFinder.Sanus.com or call 1-800-359-5520 (UK: 0800-056-2853) to find a compatible mount.

2 What is your wall made of?



Drywall with wood studs
Perfect!



Solid concrete or concrete block
Perfect!



Unsure?

Call 1-800-359-5520 (UK: 0800-056-2853)

3 Do you have all of the tools needed?

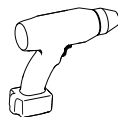
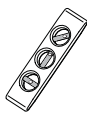

4 Ready to begin?

Please read through these instructions completely to be sure you're comfortable with this easy install process. Also check your TV owner's manual to see if there are any special requirements for mounting your TV.

If you do not understand these instructions or have doubts about the safety of the installation, assembly or use of this product, contact Customer Service at 1-800-359-5520 (UK: 0800-056-2853).

⚠ CAUTION: Avoid potential personal injuries and property damage!

- This product is designed for use in wood stud, solid concrete, and concrete block walls - DO NOT install into drywall alone
- The wall must be capable of supporting five times the weight of the TV and mount combined
- Do not use this product for any purpose not explicitly specified by manufacturer
- Manufacturer is not responsible for damage or injury caused by incorrect assembly or use

Dimensions

in.
[mm]

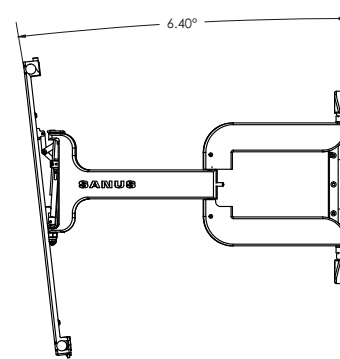
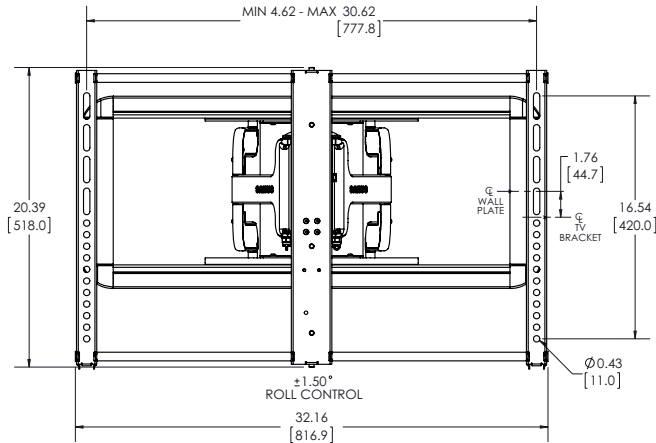
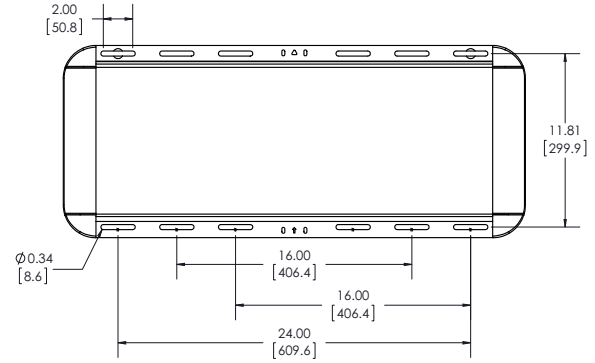
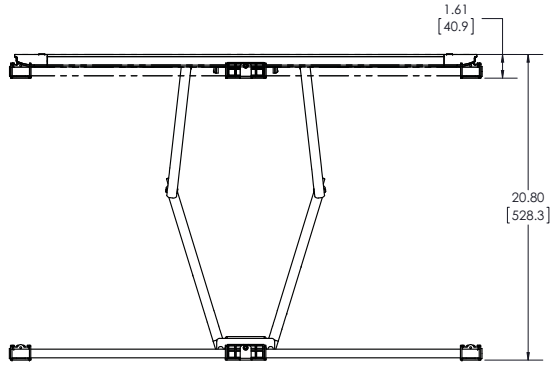

Parts and Hardware

⚠ WARNING: This product contains small items that could be a choking hazard if swallowed. Before starting assembly, verify all parts are included and undamaged. If any parts are missing or damaged, do not return the damaged item to your dealer; contact Customer Service. Never use damaged parts!

📄 NOTE: Not all hardware included will be used.

Parts and Hardware for STEP 1

TV Brackets



01 x2

TV Screws

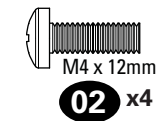

M4 x 12mm

02 x4

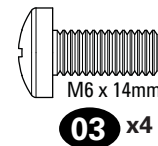

M6 x 14mm

03 x4

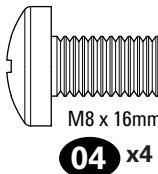

M8 x 16mm

04 x4

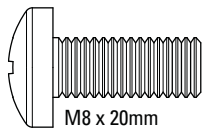

M8 x 20mm

05 x4



M4 x 30mm

06 x4

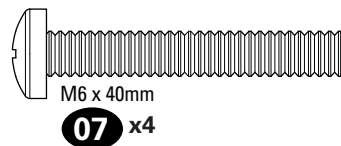

M6 x 40mm

07 x4

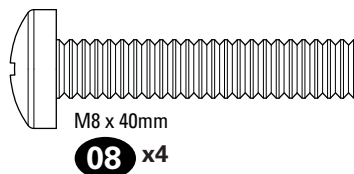

M8 x 40mm

08 x4

Washers

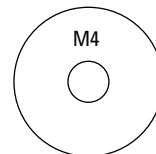

M4

09 x4

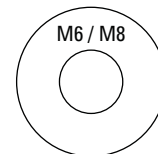

M6 / M8

10 x4

Spacers

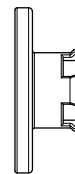

11 x4

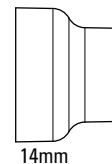

14mm

12 x4

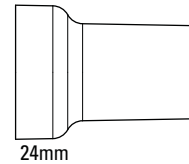

24mm

13 x4

Parts and Hardware for STEP 2

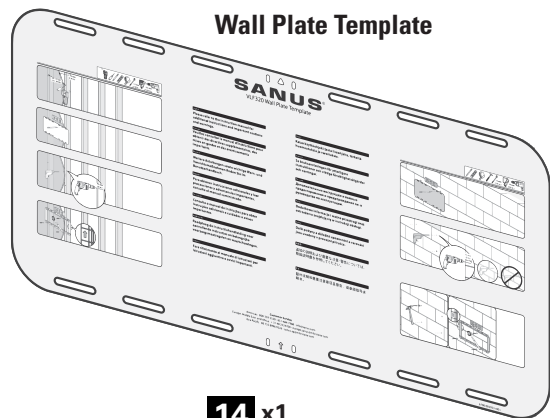

14 x1

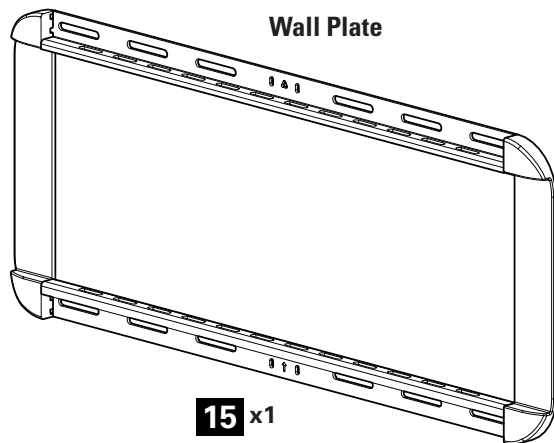

15 x1

Anchors

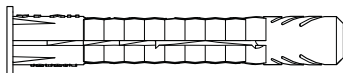

16 x4

Washers

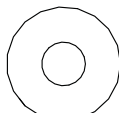

5/16 in.

17 x4

Lag Bolts

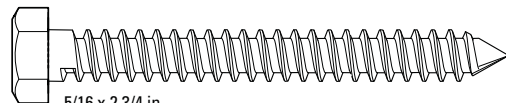

5/16 x 2 3/4 in.

18 x4

Parts and Hardware for STEP 3

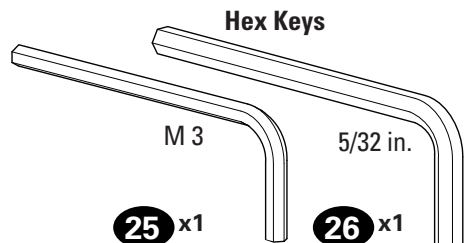
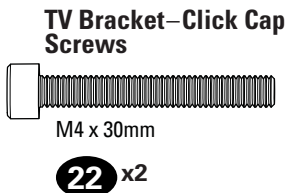
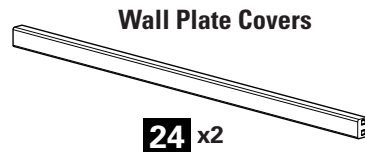
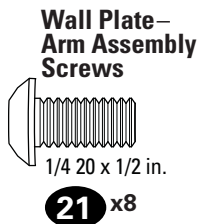
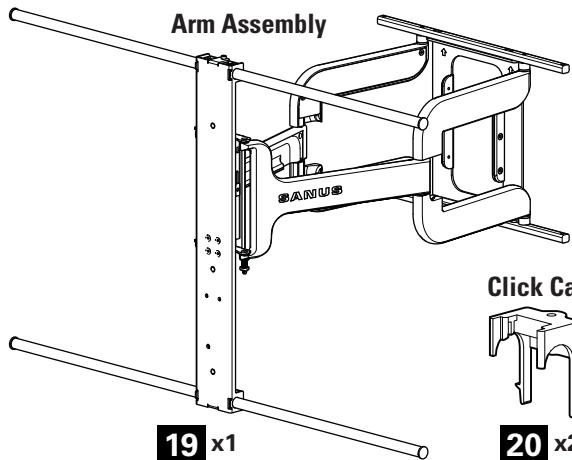

Parts and Hardware for Cable Management

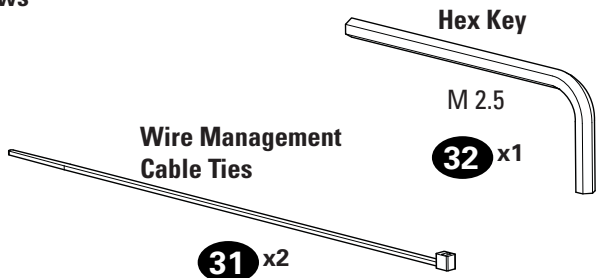
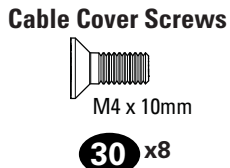
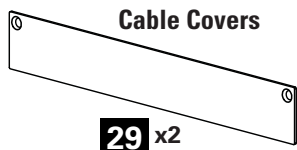
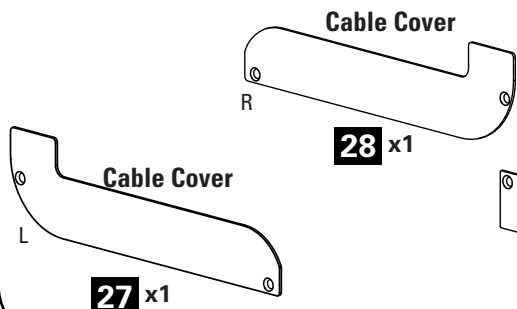

STEP 1 Attach Brackets to TV

1-1 Select TV Screws

Hand thread screws into the threaded inserts on the back of your TV to determine which screw diameter (M4, M6, or M8) to use.

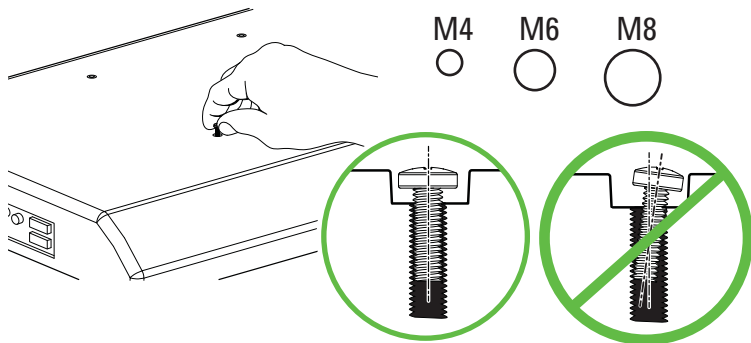

⚠ CAUTION: Verify adequate thread engagement of the screw and spacer combination on your TV.

Too short will not hold the TV and too long will damage the TV.

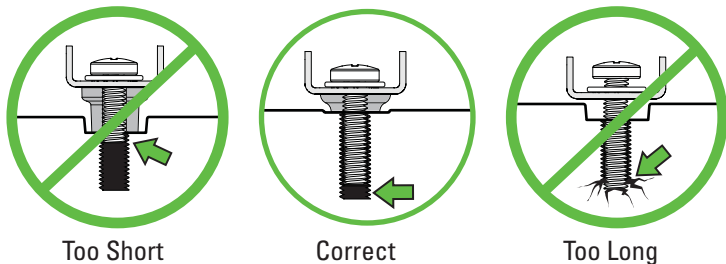

1-2 Select TV Spacers

Spacers and screws are supplied to install your TV bracket.

Determine your preference for spacer configuration when attaching your TV bracket.

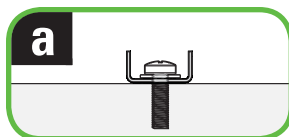

Do not use spacers if your TV has a flat back AND you want your TV closer to the wall.

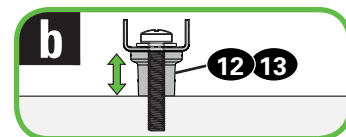

Use spacers **12** or **13** to accommodate:

- Round/irregular back TVs
- TVs with inset mounting holes
- Extra space needed for cables

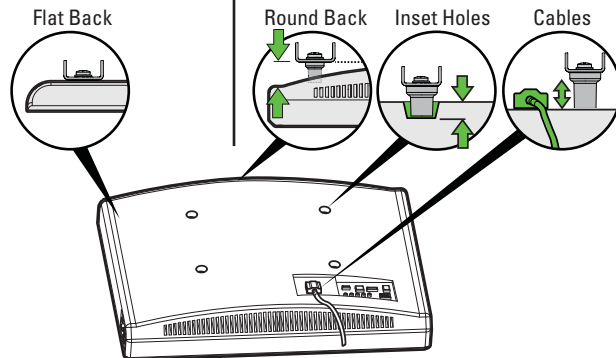

1-3 Attach Spacers to TV Brackets

 **NOTE:** Skip this step if your TV has a flat back AND you want your TV closer to the wall.

1. Press the four shoulder washers **11** through the openings of TV brackets **01** that line up with your TV hole pattern.
2. Snap the four spacers **12** or **13** you selected in STEP 1-2, onto shoulder washers **11**.

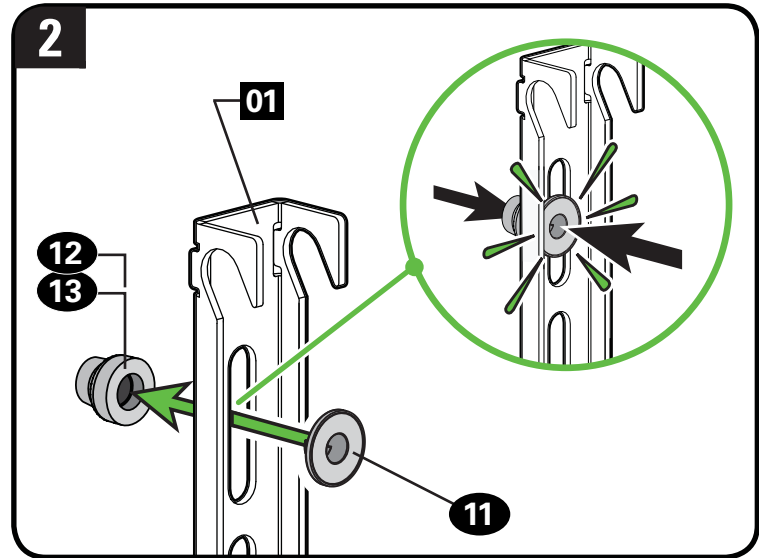
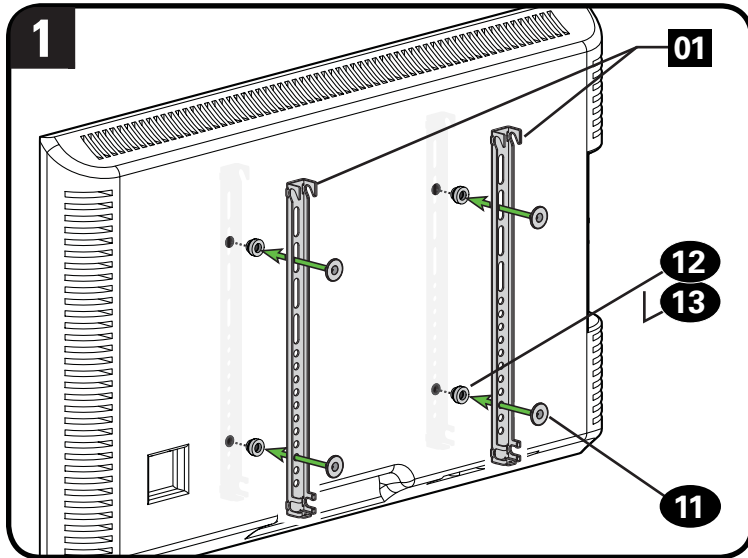

1-4 Attach TV Brackets to TV

Center the TV brackets **01** over your TV hole pattern as shown, making sure the brackets are level with each other.

Install using the screw and washer combination [a] or [b] you selected for your TV.

 **NOTE:** Use washer **09** for screws **02** and **06**.

Use washer **10** for screws **03**, **04**, **05**, **07**, and **08**.

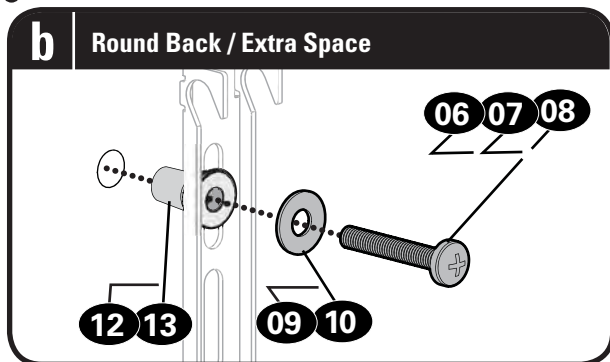
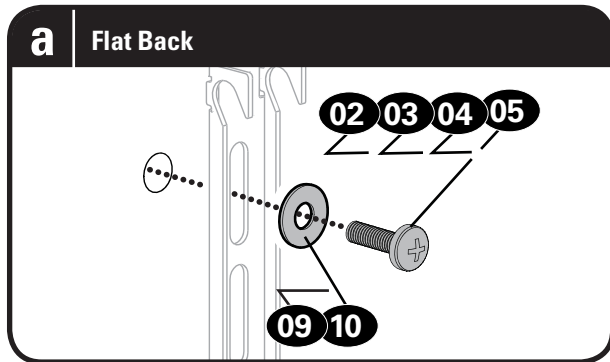
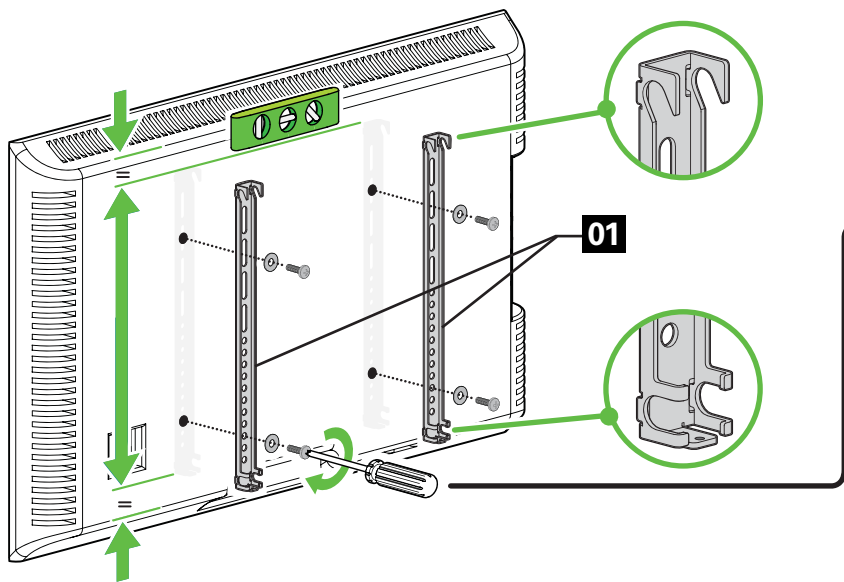

STEP 2A Attach Wall Plate to Wall Wood Stud Option

⚠ CAUTION: Avoid potential personal injuries and property damage!

- Drywall covering the wall must not exceed 5/8 in. (16 mm)
- Minimum wood stud size: common 2 x 4 in. (51 x 102 mm) nominal 1½ x 3½ in. (38 x 89 mm)
- Minimum horizontal space between fasteners: 16 in. (406 mm)

1. Stud centers must be verified – not all walls have conventional 16 in. (406 mm) stud spacing. Verify the center of the stud(s) using an awl, a thin nail, or an edge to edge stud finder.
2. Level the wall plate template **14** and mark the four hole locations.

 **NOTE:** For assistance in determining wall plate location, see HeightFinder at sanus.com.

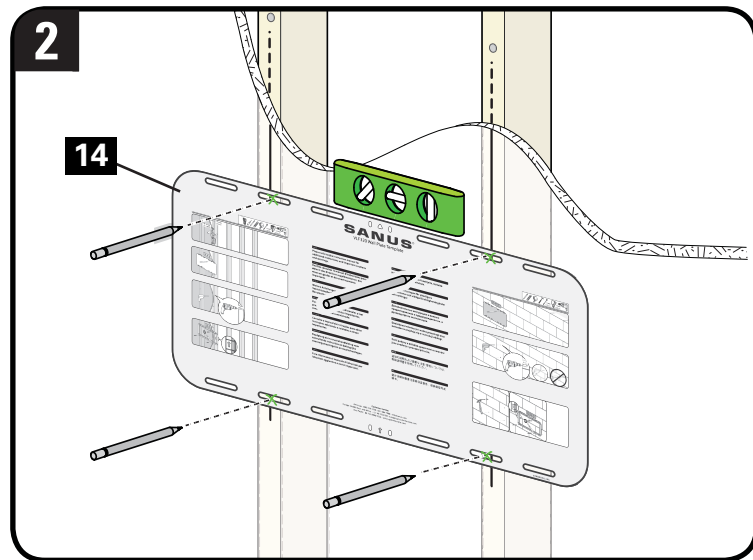
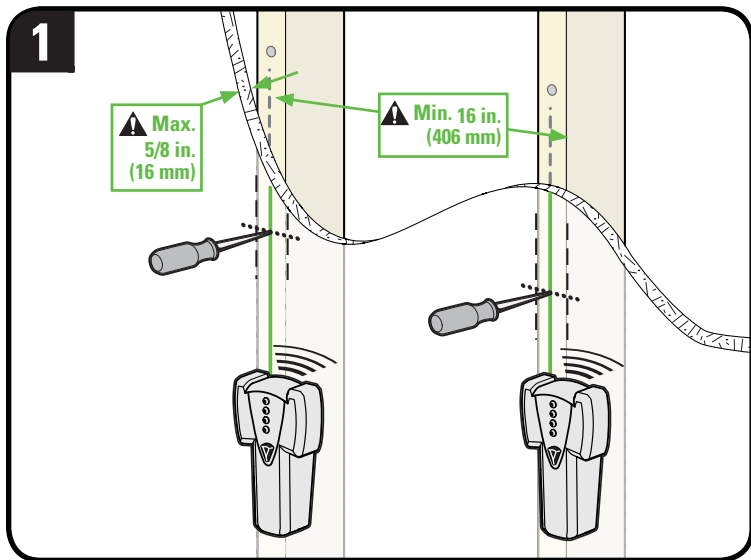

3. Drill the four pilot holes using a 7/32 in. (5.5 mm) diameter drill bit.

! IMPORTANT: Pilot holes must be drilled to a depth of 3 in. (75 mm).

4. Install the four washers **17** and lag bolts **18**. Tighten all four lag bolts **18** only until the washers **17** are pulled firmly against the wall plate **15**.

▲ CAUTION: Improper use could reduce the holding power of the lag bolts **18**. DO NOT over-tighten the lag bolts.

Go to STEP 3 on PAGE 14.

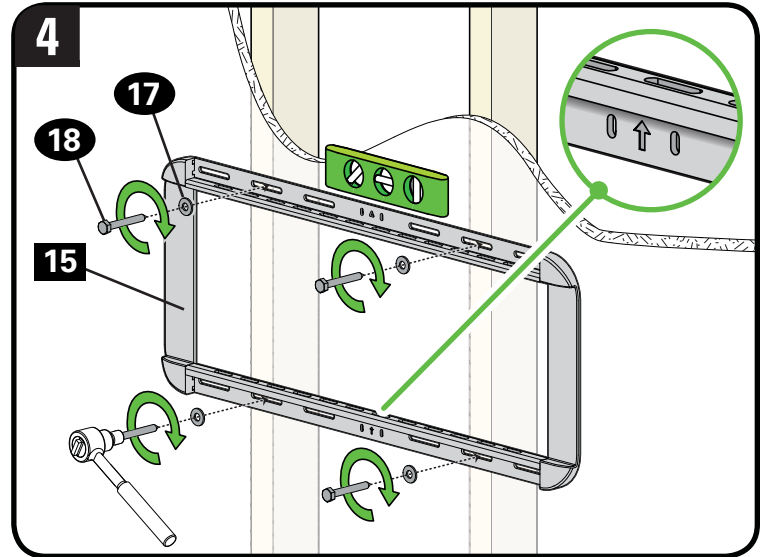
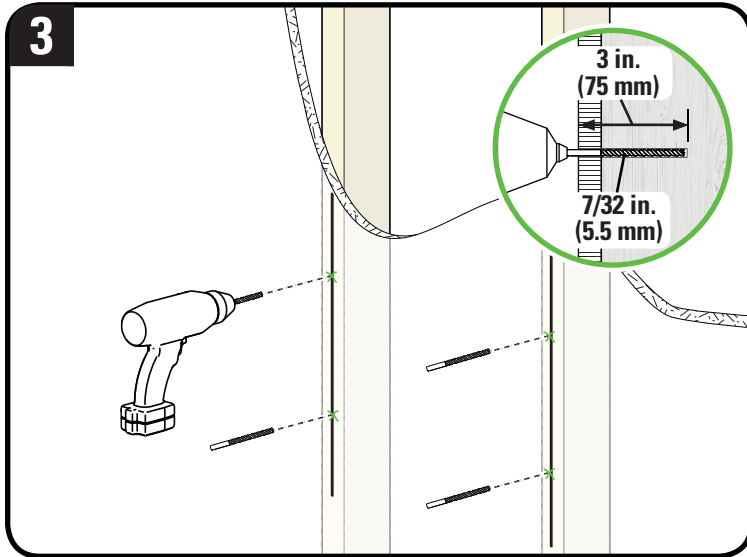

STEP 2B Attach Wall Plate to Wall Solid Concrete or Concrete Block Option

⚠ CAUTION: Avoid potential personal injuries and property damage!

- Mount the wall plate **15** directly onto the concrete surface
- Minimum solid concrete thickness: 8 in. (203 mm)
- Minimum concrete block size: 8 x 8 x 16 in. (203 x 203 x 406 mm)
- Minimum horizontal space between fasteners: 16 in. (406 mm)

1. Position the wall plate template **14** on the wall at your desired height. Level the wall plate and mark the four hole locations.

 **NOTE:** For assistance in determining wall plate location, see Height Finder at sanus.com.

2. Drill four pilot holes using a 3/8 in. (10 mm) diameter drill bit.

! IMPORTANT: Pilot holes must be drilled to a depth of 3 in. (75 mm). Never drill into the mortar between blocks.

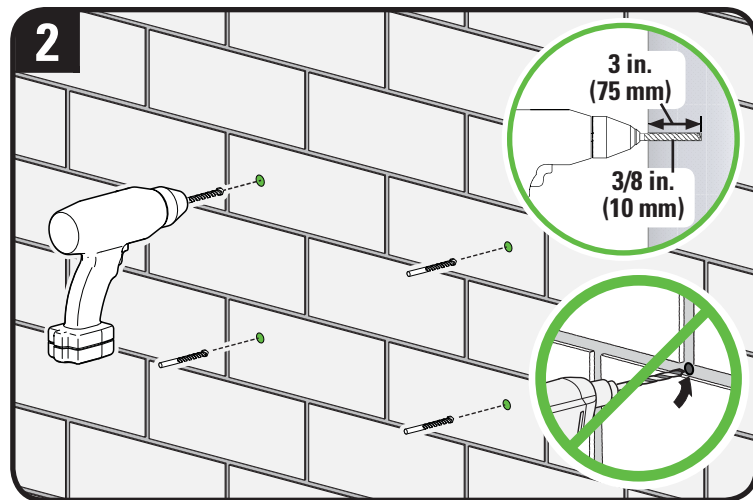
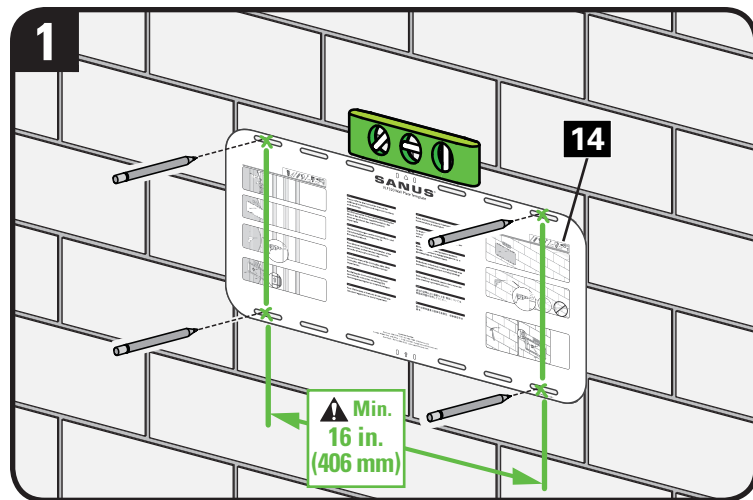

3. Insert four anchors **16**.

⚠ CAUTION: Be sure the anchors **16** are seated flush with the concrete surface.

4. Install the four washers **17** and lag bolts **18**. Tighten all four lag bolts **18** only until the washers **17** are pulled firmly against the wall plate **15**.

⚠ CAUTION: Improper use could reduce the holding power of the lag bolts **18**. DO NOT over-tighten the lag bolts.

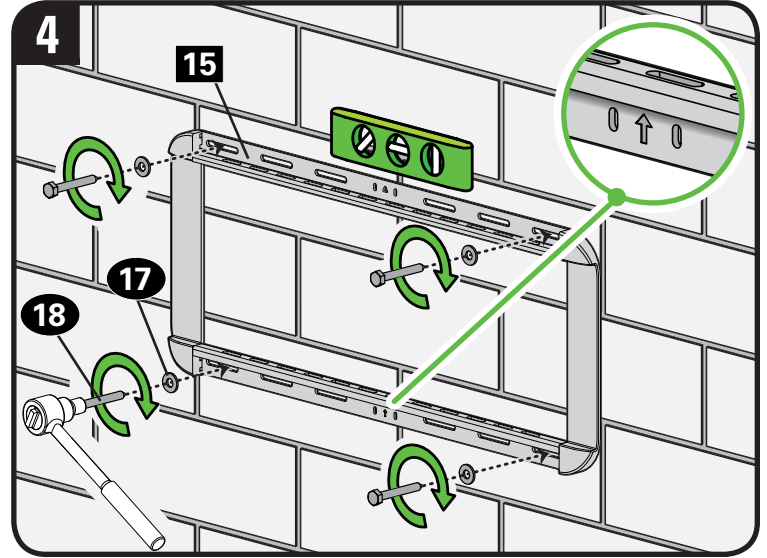
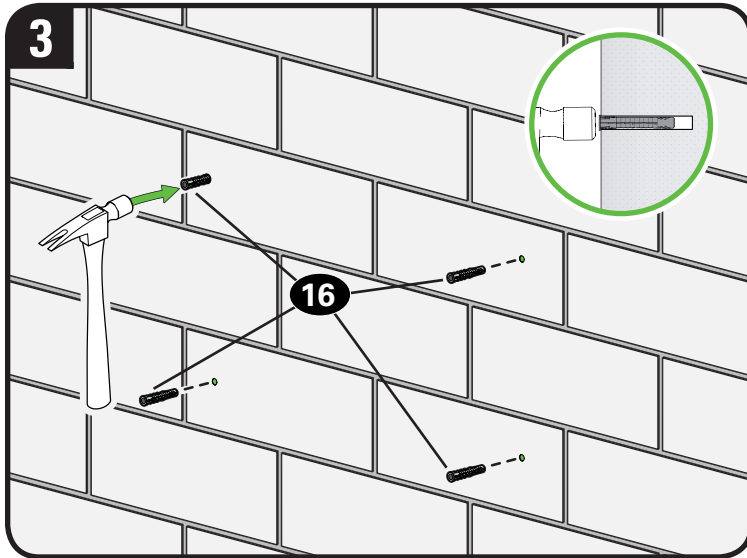

STEP 3 Attach TV to Wall Plate

3-1 Attach Arm Assembly to Wall Plate

 **NOTE:** Arm assembly **19** can be adjusted side-to-side to customize your TV installation.

1. Align four holes at the top and four at the bottom of arm assembly **19** to the slots in the wall plate **15**.
2. Secure the top portion of arm assembly **19** to the wall plate **15** with four screws **21** using hex key **26**.
3. Secure the bottom portion of arm assembly **19** to the wall plate **15** with four screws **21** using hex key **26**.

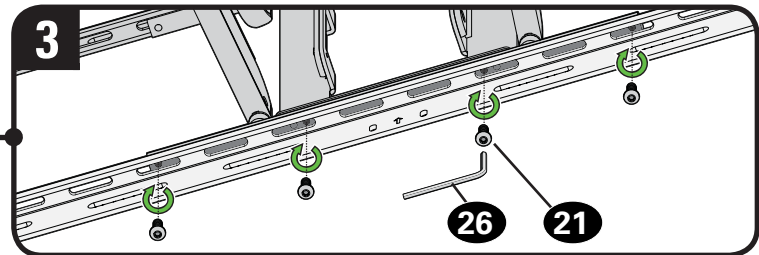
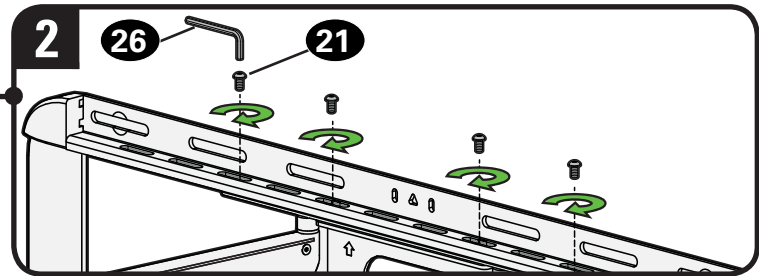
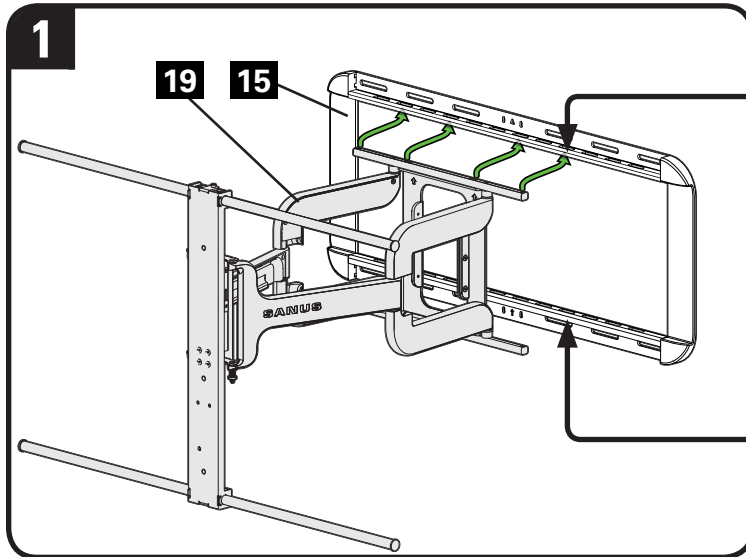

3-2 Hang TV onto Arm Assembly



HEAVY! You may need assistance with this step.

1. Hook the TV brackets **01** onto the arm assembly **19**, as shown.
2. Attach click caps **20** to TV brackets **01** with screws **22** using hex key **25**.

⚠ CAUTION: Avoid potential personal injury or property damage! Screws **22** must be installed to secure the TV onto the arm assembly **19**.

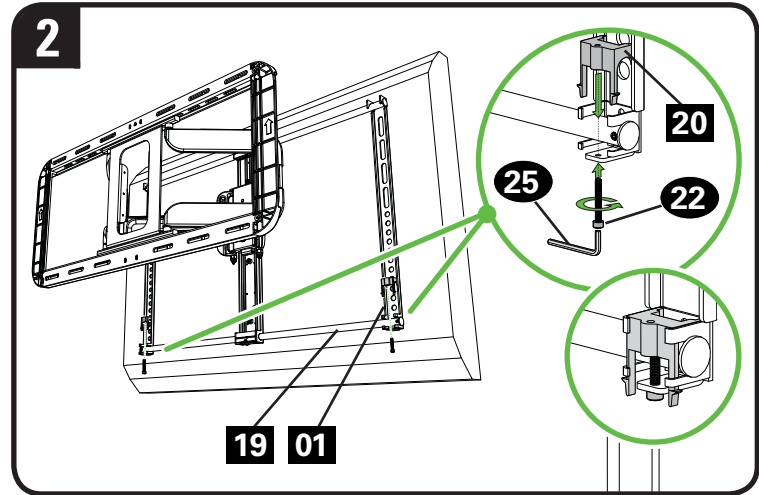
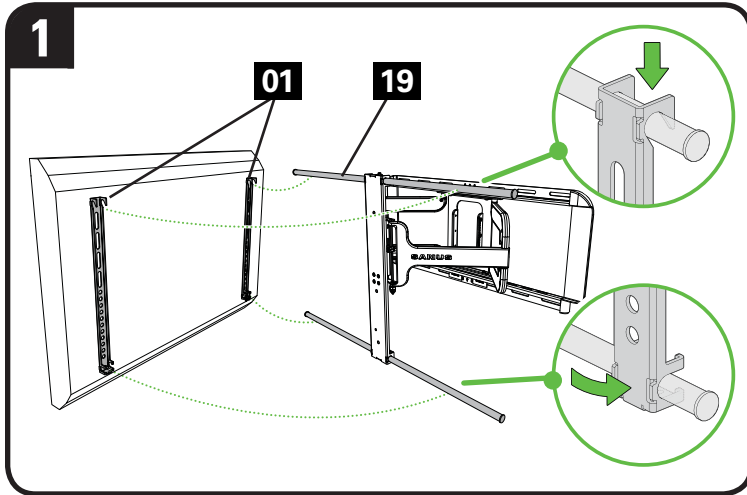

3-3 Apply Protective Felt Pads

Affix self-adhesive felt pads **23** onto the arm assembly **19** to protect your wall.

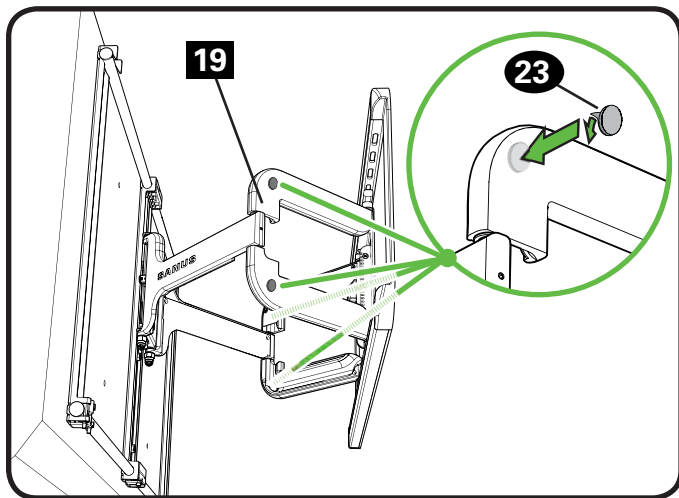

3-4 Attach Wall Plate Covers

Attach wall plate covers **24** onto wall plate **15**.

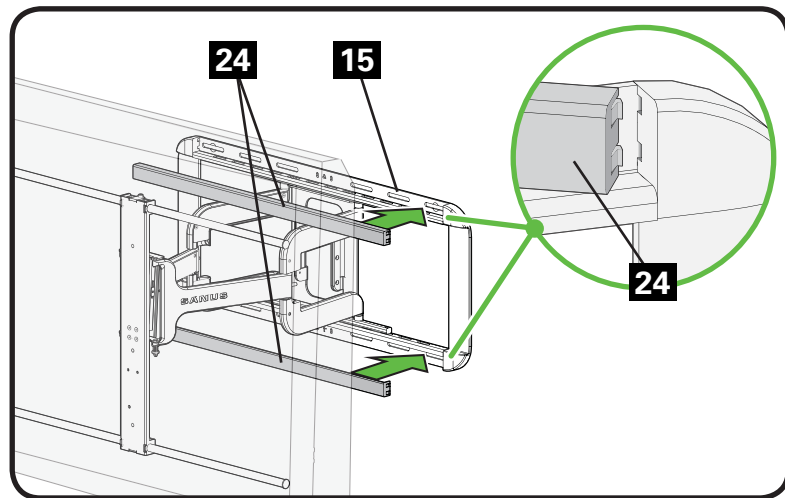

Manage Cables

1. Thread your TV cables through the channels in the middle and lower branches of the arm assembly **19**.
2. Attach cable covers **27**, **28** and **29** to the arm assembly **19**. Secure with screw **30** using hex key **32**.
3. Route cable ties **31** through the tie holders **T**.

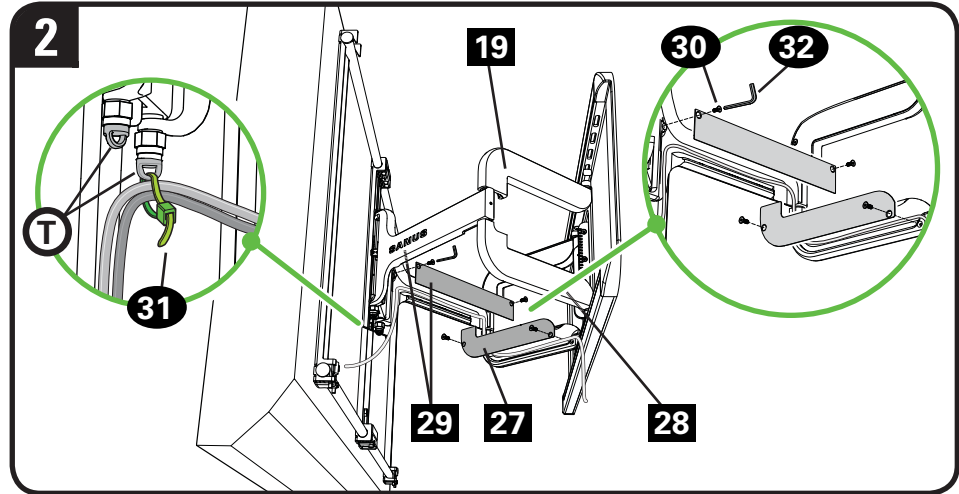
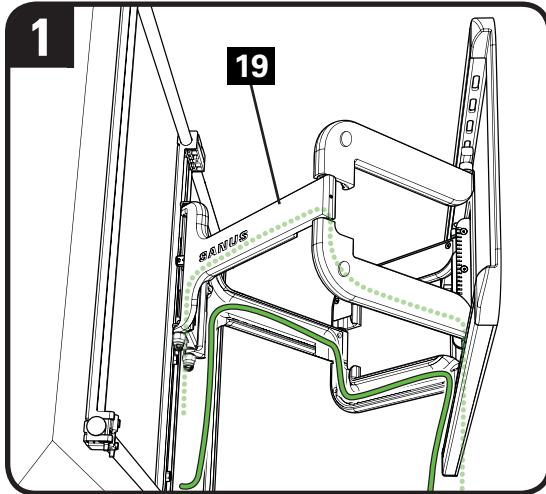

Adjustments

LEVEL



Loosen the level screw **(L)** using hex key **(26)**, adjust your TV, then tighten the level screw **(L)**.

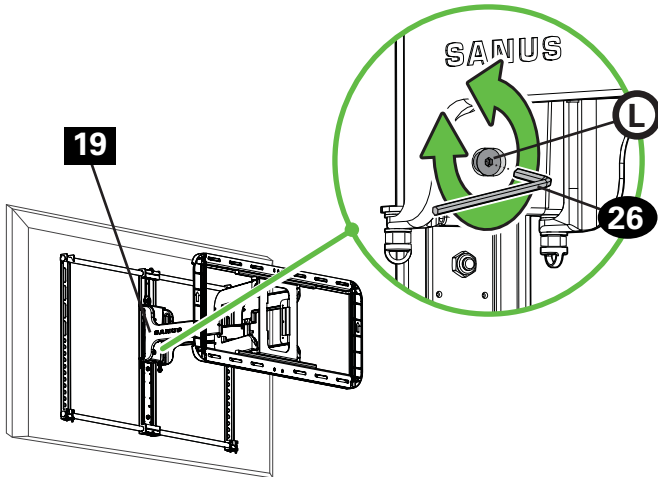

TILT

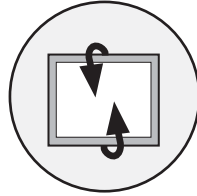

Your TV should adjust easily when moved, then stay in place.

Adjust the tilt tension knob **(K)** if your TV naturally tilts up or down.

 **NOTE:** If you do not intend to adjust the tilt for different viewing locations, you can tighten the tilt tension knob **(K)** to prevent unwanted movement.

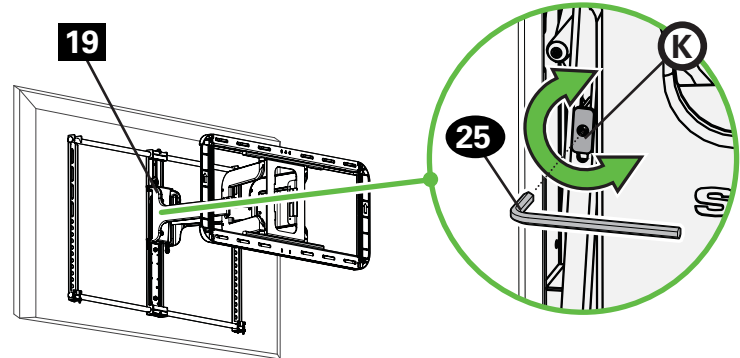

TV LATERAL SHIFT

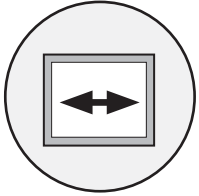

HEAVY! You may need assistance with this step.

1. Remove the TV by reversing the procedure in STEP 3-2 on PAGE 15.
2. Remove the arm assembly **19** by reversing the procedure in STEP 3-1 on PAGE 14.
3. Reposition the arm assembly **19** (STEP 3-1 on PAGE 14).
4. Reattach the TV (STEP 3-2 on PAGE 15).

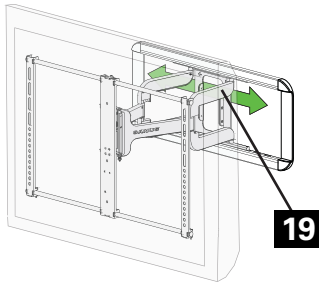

REMOVING THE TV

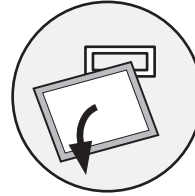

HEAVY! You may need assistance with this step.

1. Remove the TV by reversing the procedure in STEP 3-2 on PAGE 15.
2. Remove the arm assembly **19** by reversing the procedure in STEP 3-1 on PAGE 14.

Antes de comenzar, verifiquemos si este soporte es el adecuado para usted.

1 ¿Su televisor pesa *más* de 54 kg (120 lb) incluyendo los accesorios?



No — ¡Perfecto!

Sí — Este soporte NO es compatible. Visite MountFinder.Sanus.com o llame al 1-800-359-5520 (Reino Unido: 0800-056-2853) para encontrar un soporte compatible.

2 ¿De qué está hecha su pared?



Tabiques de yeso con montantes de madera
¡Perfecto!



Hormigón sólido o bloques de cemento
¡Perfecto!



¿No está seguro?

Llame al 1-800-359-5520 (Reino Unido: 0800-056-2853)

3 ¿Tiene todas las herramientas necesarias?

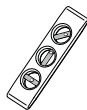

5,5 mm
(7/32")
Madera



10 mm
(3/8")
Hormigón



13 mm
(1/2")

4 ¿Listo para comenzar?

Lea estas instrucciones en su totalidad para sentirse seguro y cómodo con este fácil proceso de instalación. Consulte igualmente el manual del usuario de su televisor para saber si existe algún requisito especial para instalar su televisor en la pared.

Si no entiende las instrucciones o si tiene dudas acerca de la seguridad de la instalación, del ensamblado o del uso del producto, póngase en contacto con el servicio de atención al cliente al 1-800-359-5520 (Reino Unido: 0800-056-2853).

▲ PRECAUCIÓN: Evite posibles lesiones personales y daños materiales.

- Este producto fue diseñado para su uso en paredes de montantes de madera, hormigón sólido y bloques de cemento - NO instalar en yeso solo
- La pared debe soportar cinco veces el peso del televisor y del soporte juntos
- No utilice este producto para ningún otro propósito que no sea el explícitamente especificado por el fabricante
- El fabricante no se responsabiliza por ningún daño o lesión resultante del montaje incorrecto o del uso indebido

Piezas y elementos de sujeción

▲ ADVERTENCIA: Este producto contiene piezas pequeñas que, si fuesen tragadas, podrían producir asfixia. Antes de iniciar el ensamblaje, compruebe que todas las piezas estén incluidas y en buenas condiciones. Si faltan piezas o alguna está dañada, no devuelva el artículo al distribuidor. Póngase en contacto con el servicio de atención al cliente. Nunca utilice piezas deterioradas.

 **NOTA:** No todos los elementos de sujeción incluidos deberán utilizarse.

PASO 1 Colocar la placa de sujeción en el televisor

1-1 Seleccione los tornillos del televisor

Enrosque manualmente los tornillos en los encastres roscados del dorso del televisor a fin de determinar qué diámetro de tornillos (M4, M6 o M8) debe utilizar.

▲ PRECAUCIÓN: Verifique que el tornillo o la combinación de tornillo y espaciador enrosquen correctamente. Si el tornillo es demasiado corto, no sostendrá el televisor. Si es demasiado largo, el aparato se dañará.

1-2 Seleccione los espaciadores del televisor

Se incluyen espaciadores y tornillos para instalar el soporte de su televisor. Defina su preferencia para la configuración del espaciador cuando fije el soporte de su televisor.

No use los espaciadores si el dorso de su televisor es plano Y quiere que su televisor esté más cerca de la pared.

Utilice los espaciadores **12** o **13** para acomodar: televisores con dorso redondeado o irregular, televisores con orificios de montaje intercalados y en caso de necesitar un espacio adicional para cables.

1-3 Acople los espaciadores para las placas de sujeción del televisor

 **NOTA:** Sautez cette étape si votre téléviseur est doté d'un dos plat et que vous voulez de votre téléviseur près du mur.

1. Presione las cuatro arandelas con reborde **11** a través de los orificios correspondientes de las placas de sujeción **01** que se alinean con el patrón de orificios de su televisor.
2. Fije los cuatro espaciadores **12** o **13** que seleccionó en el PASO 1-2 a las arandelas con reborde **11**.

1-4 Acople las placas de sujeción del televisor

1. Centre el soporte del televisor **01** en el patrón de orificios como se indica en la ilustración, asegurándose de que los soportes estén nivelados. Haga la instalación utilizando la combinación de espaciadores, tornillos y arandelas que seleccionó para su televisor.



 **NOTA:** Utilice la arandela **09** para los tornillos **02** y **06**. Utilice la arandela **10** para los tornillos **03**, **04**, **05**, **07** y **08**.

 **NOTA:** Se ilustran las configuraciones estándar. Si desea información sobre aplicaciones especiales o si tiene dudas sobre la selección de piezas, póngase en contacto con el servicio de atención al cliente.

PASO 2A Fijar la placa mural a la pared Opción para montantes de madera

Ver PÁGINA 10

 **PRECAUCIÓN:** Evite posibles lesiones personales y daños materiales.

- El yeso que recubre la pared no debe exceder los 16 mm (5/8")
 - Tamaño mínimo del montante de madera: común 51 x 102 mm (2" x 4") nominal 38 x 89 mm (1½" x 3½")
 - Espacio horizontal mínimo entre los elementos de sujeción: 406 mm (16")
1. Los montantes centrales deben verificarse: no todas las paredes tienen un espaciado convencional entre montantes de 406 mm (16"). Verifique el centro de los montantes con un punzón o un clavo delgado o bien utilice un detector de bordes de montantes.
 2. Nivele la plantilla de la placa mural **14** y marque la ubicación de los orificios.
 **NOTA:** Si necesita ayuda para determinar la ubicación de la placa mural, utilice la herramienta HeightFinder disponible en sanus.com.
 3. Haga los cuatro orificios guía con una mecha de 5,5 mm (7/32") de diámetro.
 **IMPORTANTE:** Los orificios guía deben realizarse hasta una profundidad de 75 mm (3").
 4. Instale las cuatro arandelas **17** y los tornillos tirafondo **18**. Ajuste los tornillos tirafondo **18** solamente hasta que las arandelas **17** queden firmes contra la placa mural **15**.

 **PRECAUCIÓN:** El uso indebido podría reducir la capacidad de retención de los tornillos tirafondo **18**. NO ajuste en exceso los tornillos tirafondo. Vaya al PASO 3 en la PÁGINA 14.

PASO 2B Fijar la placa mural a la pared

Opción para hormigón sólido o bloques de cemento

Ver PÁGINA 12

⚠ PRECAUCIÓN: Evite posibles lesiones personales y daños materiales.

- Instale la placa mural **15** directamente sobre la superficie de hormigón
- Espesor mínimo del hormigón: 203 mm (8")
- Tamaño mínimo del bloque de cemento: 203 x 203 x 406 mm (8" x 8" x 16")
- Espacio horizontal mínimo entre los elementos de sujeción: 406 mm (16")

1. Coloque la plantilla de la plantilla de la placa mural **14** en la pared a la altura que desee. Nivele la placa mural y marque las ubicaciones de los cuatro orificios.

 **NOTA:** Si necesita ayuda para determinar la ubicación de la placa mural, utilice la herramienta HeightFinder disponible en sanus.com.

2. Haga los cuatro orificios guía con una mecha de 10 mm (3/8") de diámetro.

! IMPORTANTE: Los orificios guía deben realizarse hasta una profundidad de 75 mm (3"). Nunca perforo el cemento que une los bloques.

3. Inserte los cuatro anclajes para hormigón **16**.

⚠ PRECAUCIÓN: Cerciórese de que los anclajes **16** queden nivelados respecto de la superficie de hormigón.

4. Instale las cuatro arandelas **17** y los tornillos tirafondo **18**. Ajuste los cuatro tornillos tirafondo **18** solamente hasta que las arandelas **17** queden firmes contra la placa mural **15**.

⚠ PRECAUCIÓN: El uso indebido podría reducir la capacidad de retención de los tornillos tirafondo **18**. NO ajuste en exceso los tornillos tirafondo.

PASO 3 Acoplar el televisor a la placa mural

Ver PÁGINA 14

3-1 Fije el módulo del brazo a la placa mural

 **NOTA:** El módulo del brazo **19** puede ajustarse horizontalmente a fin de personalizar la instalación del televisor.

1. Alinee los orificios superiores e inferiores el módulo del brazo **19** con las ranuras de la placa mural **15**.

2. Fije parte superior del conjunto el módulo del brazo **19** a la placa mural **15** utilizando los cuatro tornillos suministrados **21**. Ajústelos con la llave hexagonal **26**.

3. Fije parte inferior del conjunto el módulo del brazo **19** a la placa mural **15** utilizando los cuatro tornillos suministrados **21**. Ajústelos con la llave hexagonal **26**.

3-2 Cuelgue el televisor en el módulo del brazo



¡ELEMENTO PESADO! Es posible que necesite ayuda en este paso.

1. Asegúrese de enganchar los soportes del televisor en la placa de conexión, como se muestra en la ilustración.
2. Fije las tapas **20** a la placa de conexión **01** utilizando los tornillos **22**. Ajústelos con la llave hexagonal **25**.

▲ PRECAUCIÓN: Evite el riesgo de lesiones y daños materiales. Los tornillos **22** debe instalarse para fijar el televisor al ensamblaje del brazo **19**.

3-3 Aplicar protectores de fieltro

Coloque almohadillas de fieltro autoadhesivas **23** en el conjunto el módulo del brazo **19** para proteger su pared.

3-4 Acople cubiertas de la placa de pared

Coloque las cubiertas de la placa mural **24**.

Organizar los cables

Ver PÁGINA 17

1. Pase los cables del televisor por los canales ubicados en las secciones media e inferior el módulo del brazo **19**.
2. Coloque las cubiertas para cables **27**, **28** y **29** en el módulo del brazo **19**. Fijelas con los tornillos suministrados **30**.
3. Pase los sujetacables **31** por el soporte para sujetacables **T**.



Ajustes

NIVEL

Afloje el tornillo de nivel  utilizando la llave hexagonal , ajuste su televisor y vuelva a ajustar el tornillo de nivel .

INCLINACIÓN



El televisor debe acomodarse fácilmente al moverlo y, posteriormente, quedar en su lugar. Si el televisor se inclina hacia arriba o hacia abajo de forma natural, ajuste la perilla de tensión de inclinación  a mano.

 **NOTA:** Si no pretende ajustar la inclinación a diferentes ubicaciones de visión, puede ajustar la perilla de tensión de inclinación  para evitar movimientos no deseados.

DESPLAZAMIENTO LATERAL DEL TELEVISOR



¡ELEMENTO PESADO! Es posible que necesite ayuda en este paso.

1. Para retirar el televisor: (revierta los procedimientos en el PASO 3-2 en la PÁGINA 15).
2. Para retirar el módulo del brazo  : (revierta los procedimientos en el PASO 3-1 en la PÁGINA 14).
3. Vuelva a colocar el módulo del brazo  (PASO 3-1 en la PÁGINA 14).
4. Vuelva a colocar el televisor (PASO 3-2 en la PÁGINA 15).

EXTRACCIÓN DEL TELEVISOR



¡ELEMENTO PESADO! Es posible que necesite ayuda en este paso.

1. Para retirar el televisor: (revierta los procedimientos en el PASO 3-2 en la PÁGINA 15).
2. Para retirar el módulo del brazo  : (revierta los procedimientos en el PASO 3-1 en la PÁGINA 14).

SANUS®

SANUS®

Thank you for choosing Sanus! Please take a moment to let us know how we did:



Call us: 1-800-359-5520
UK: 0800 056 2853



Email us: info@sanus.com



Leave a review: [sanus.com](https://www.sanus.com)



Like us on [Facebook.com/sanussystems](https://www.facebook.com/sanussystems)



Follow us on Twitter: [@sanussystems](https://twitter.com/sanussystems)

Milestone AV Technologies and its affiliated corporations and subsidiaries (collectively, "Milestone"), intend to make this manual accurate and complete. However, Milestone makes no claim that the information contained herein covers all details, conditions, or variations. Nor does it provide for every possible contingency in connection with the installation or use of this product. The information contained in this document is subject to change without notice or obligation of any kind. Milestone makes no representation of warranty, expressed or implied, regarding the information contained herein. Milestone assumes no responsibility for accuracy, completeness or sufficiency of the information contained in this document.

©2014 Milestone AV Technologies. All rights reserved. Sanus is a division of Milestone.
All other brand names or marks are used for identification purposes and are trademarks of their respective owners.

SANUS • 6436 City West Parkway • Eden Prairie, MN 55344 USA

6901-002344 00