

LIVI 502

Electromechanical automation for swing gates
up to 4,5 m - 400 kg



For residential and
commercial usage



Available in 230V and 24V



LIVI 502



Compatible with external cable release (art.560M and art. BLINDOS - optional), to always have safe access from outside the property



Quick release with customised metal key, protected from the weather.

You can mount the operator also in a perpendicular way compared to the door, with vertical mounting plate (art. 560P)

Door opening up to 135°.

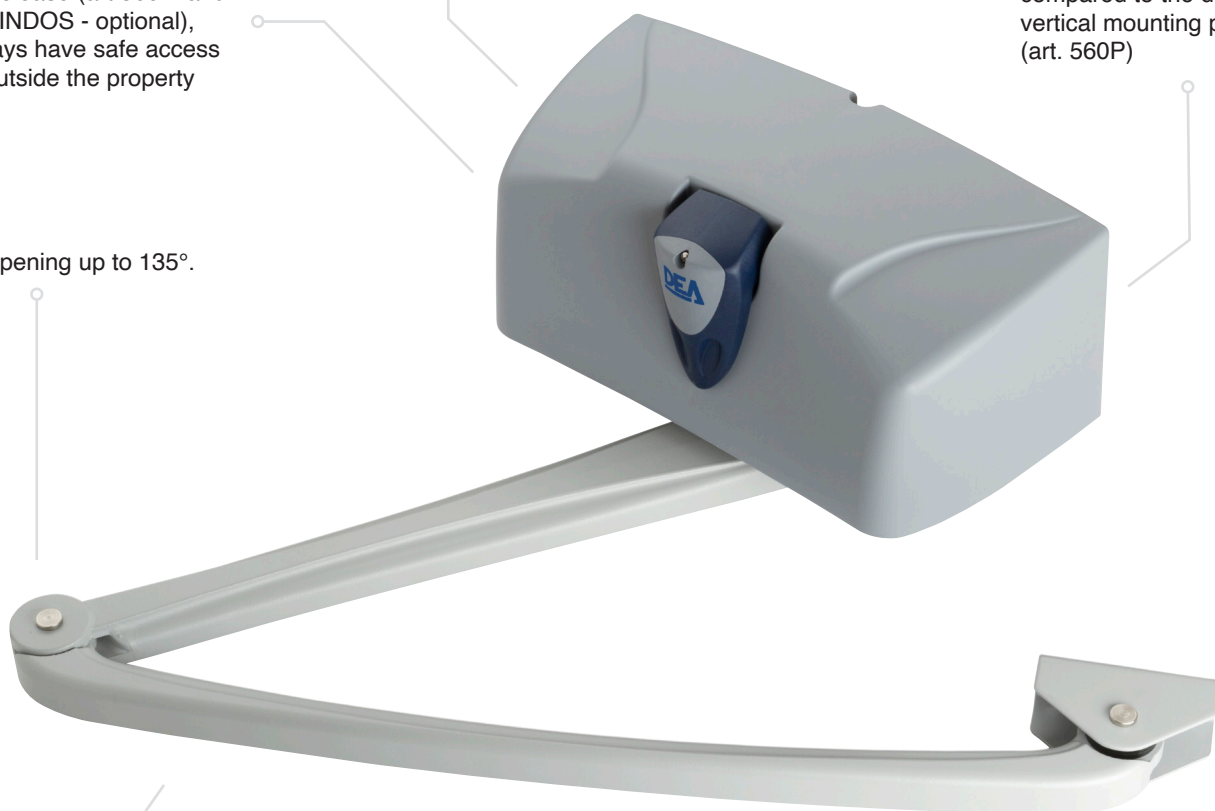

Sliding rail (optional) to avoid lateral obstructions



The DE@NET universal control board make this operator compatible with NETLINK System.

p.11



Compatible with NETCOM, the device for installation maintenance and remote control management!



Models

230V ~ operators without control board and arm



COD.	Art.			OTHER CHARACTERISTICS
623120	502	●		• For leaves up to 3m length
623140	502L	●		• Slow version, for leaves up to 4,5m length
623121	502EN	●	✓	• With encoder, for leaves up to 4,5m length

All models have: arm not included. Horizontal mounting plates included.
Control board to complete the installation: control board cod. 677610 art. NET230N/C (with box)

24V = operators without control board and arm



COD.	Art.			OTHER CHARACTERISTICS
623180	502/24	●●		• For leaves up to 3m length

All models have: arm not included. Horizontal mounting plates included.
Control board to complete the installation: control board cod. 678261 art. NET24N/C (with box)

Technical info

TECHNICAL INFO	502 - 502EN	502L	502/24
Motor power supply (V)	230V ~ ± 10 % (50/60 Hz)		24V =
Maximum power absorption (W)	300		80
Max torque (Nm)	295	260	180
Duty cycle (cycles/hours)	22 -25 (vers. 502EN)		35
N. max cycles in 24h.	110		140
Built-in capacitor (µF)	8		/
Operating temperature (°C)	-20 ÷ 50		
Motor thermal protection (°C)	150		/
90° Opening time (s)	12	18	10
Weight with packing (Kg)	13,5		13,2
Sound pressure (dBA)	< 70		
Protection level	IP44		

Example of a typical installation

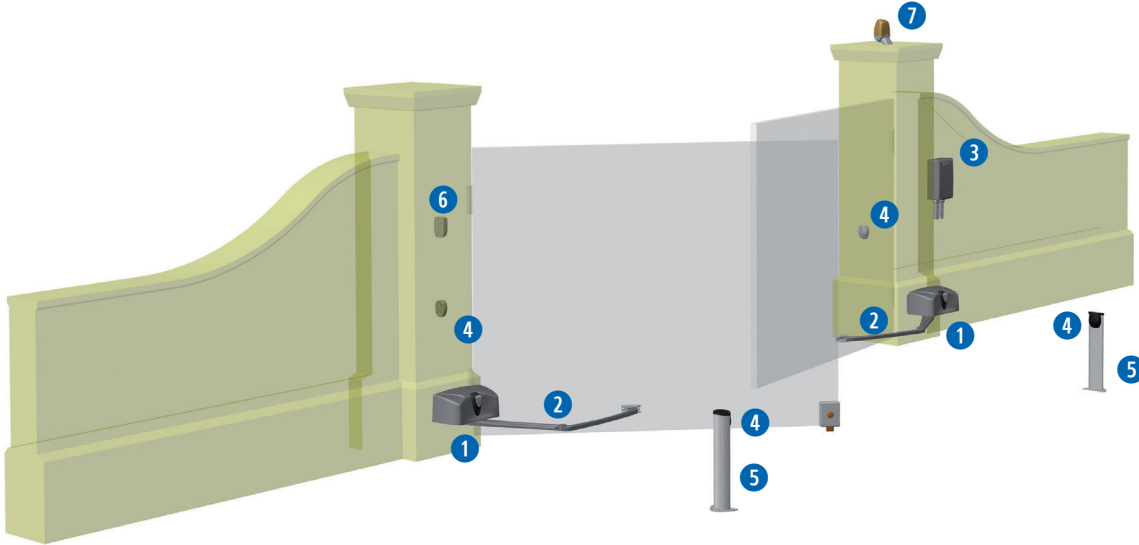

KIT

1  **COD. 623140**
Art. 502L
Electromechanical automation for swing gates

KIT

2  **COD. 629130**
Art. 560A
Aluminium articulated arm

KIT

3  **COD. 677610**
Art. NET230N/C
Universal digital control board for 1 or 2 operators, 230V with or without magnetic encoder (with box)

KIT

4  **COD. 662080**
Art. LINEAR/XS
Pair of mini synchronizable photocell for outdoor installation. Maximum range 20m

5  **COD. 664000**
Art. PILLY/60
55cm column for photocell (2 pcs)

6  **COD. 663090**
Art. GT-KEY
Metal vandal proof keyswitch with two contacts, surface mounted. Supplied with 2 keys.

KIT

6  **COD. 661130**
Art. AURA N
Multi-voltage LED flashing light 24AC-DC / 120AC / 230AC and with integrated 433MHz / 868MHz antenna

KIT

COD. 672645
Art. GTI4
Serialized white 4-channel remote control, 433 MHz, with 3 coding: HCS Rolling-Code, Dip-Switch and new D.A.R.T. coding

 **COD. 668010**
Art. 127
Warning sign

KIT for further details on the kits see price list

Specific accessories

 **COD. 380960**
Art. 560P
Vertical fixing plate (fastening of operator perpendicularly to the gate)

 **COD. 629100**
Art. 560M
External unlocking device by cable (4,5m). To be used with BLINDOS

 **COD. 665000**
Art. BLINDOS
Aluminium safety enclosure, with European cylinder, ready for unlocking device by cable.

 **COD. 629350**
Art. KIT CLIMB
Adapter set for doors on slopes (for doors up to 2m - 150 kg; max gradient 12%)

 **COD. 629250**
Art. COL 515
Anti-fall Stainless steel cable with 2 holes for swing gates

 **COD. 639111**
Art. 560F - 960F
Limit switches set

 **COD. 629330**
Art. SD502
Junction box

 **COD. 629130**
Art. 560A
Aluminium articulated arm

 **COD. 629140**
Art. 560BV
Painted galvanized steel articulated arm

 **COD. 629110**
Art. 560BD
Galvanized steel rail sliding arm, right side (L. 800 mm)

 **COD. 629120**
Art. 560BS
Galvanized steel rail sliding arm, left side (L. 800 mm)

Guide to use

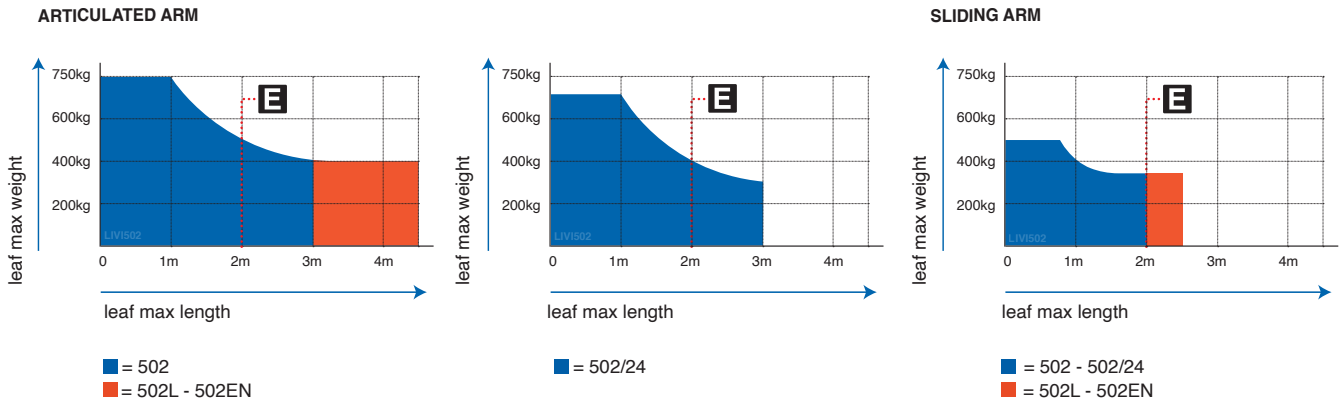

If the leaf length is bigger than 2m or if you use reversible models you must install the electric-lock to block the gate in closed position. The height and the leaf structure, as well as the presence of strong wind, can cause the reduction of the value of the data contained in table or make it necessary to use an electric lock also for leaves shorter than 2m.

Wiring

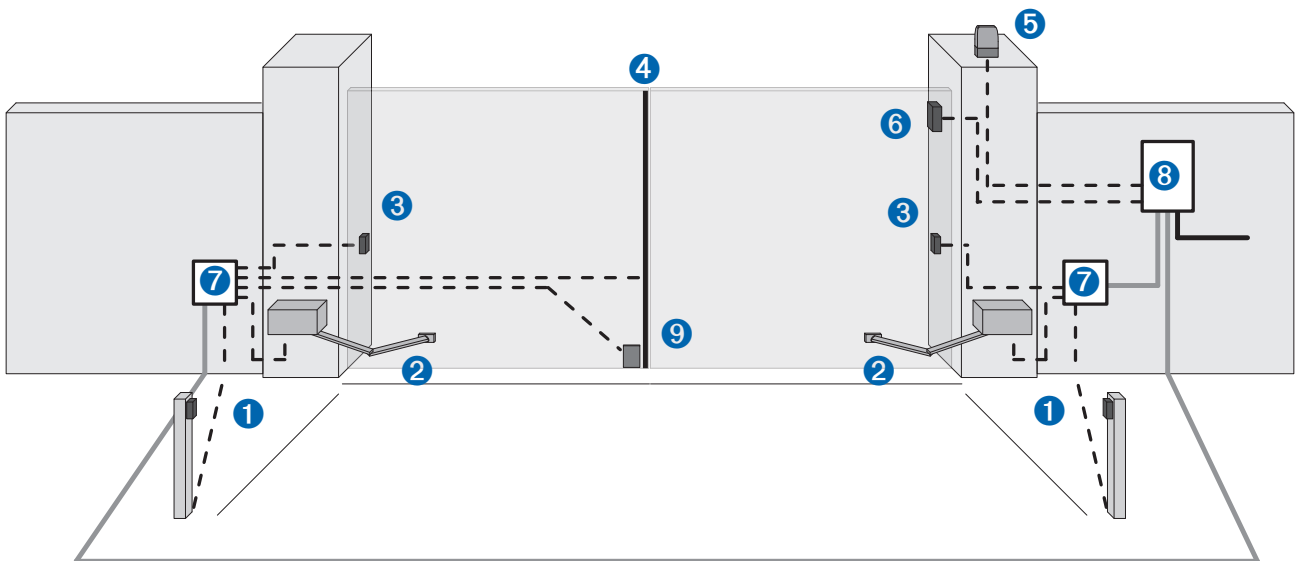

- Corrugated pipe for power supply cable
- Ø40 corrugated pipe for connection between the control board and the junction box
- - - Ø20 corrugated pipe or external PVC conduit for connection between the control board and the command and safety accessories

pos.	description
1	Column with photocells
2	Operator
3	Photocells
4	Safety edge
5	Flashing light
6	Keyswitch / Digicode
7	Junction box
8	Control board
9	Electric-lock

Dimensions

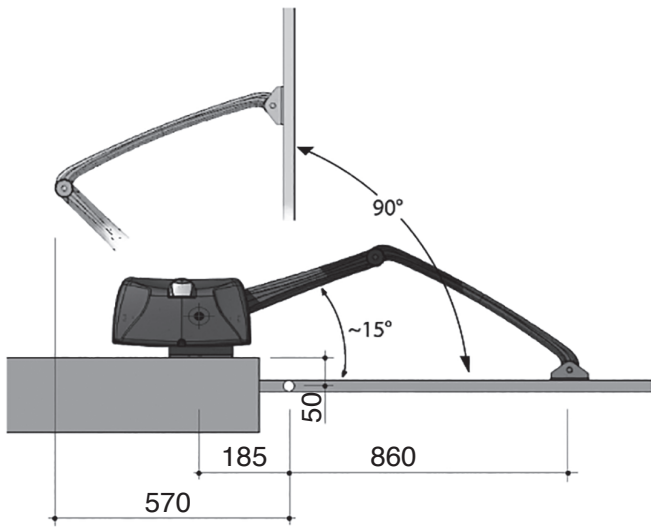
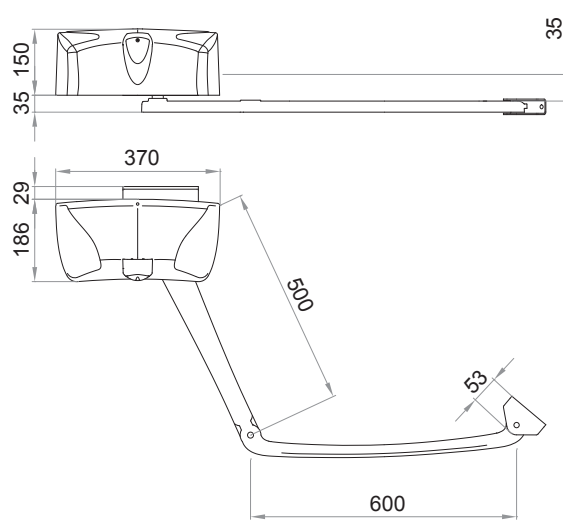

art. 560A + BV

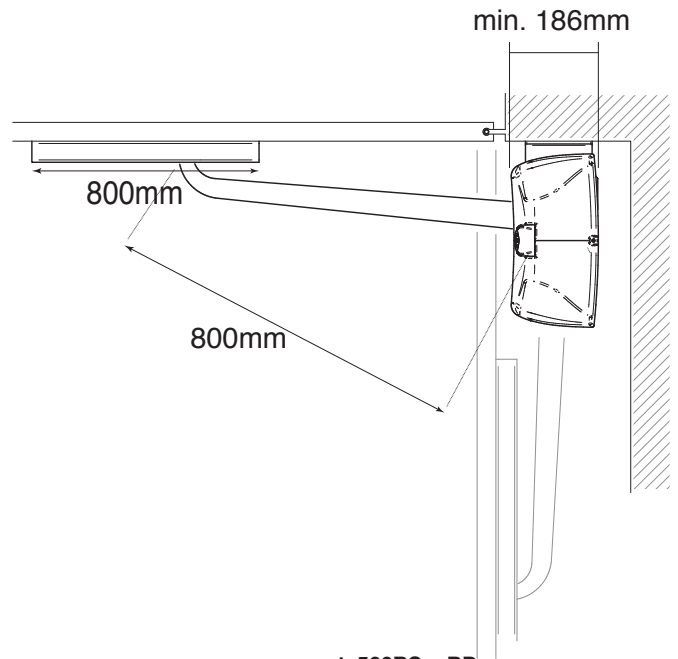

art. 560BS + BD



Dimensions

LIVI 502 with Art. 560A					
A	B	C	D	E	F
20	200	860	90°	372	-
50	200	840	90°	392	-
100	200	820	90°	418	-
120	200	820	90°	424	-
150	200	800	90°	438	-
200	200	800	90°	452	-
250	200	800	90°	464	-
300	200	800	90°	472	-
350	200	780	90°	482	-
0	390	680	135°	498	208
20	390	680	130°	522	140
20	300	760	120°	532	75
20 ÷ 50	250	800	110°	520	-
50 ÷ 100	220	810	100°	482	-

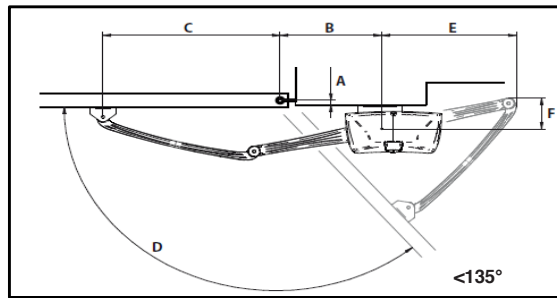
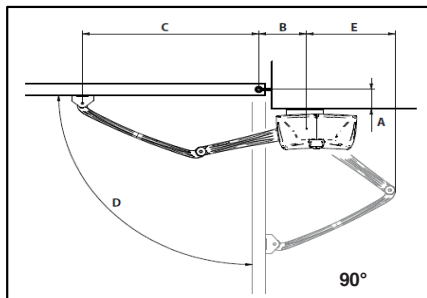

DEAuser



DEAuser is the app for **private users** that allows activation of automation at **close proximity** via Bluetooth.

By installing the NET-NODE on all devices with NETLINK technology, users can control their automations through their smart devices.

To be used with:



Art.NET-NODE
Cod.677640



DEAinstaller



DEAinstaller is the App dedicated to the **professional installer** and allows Installers to program and manage DEA automations on-site in a simple and intuitive way from their smart devices.

If you use it with the NET-NODE you can:

- ✓ keep a **data backup** of all installations
- ✓ easily adjust the **parameters** of control boards
- ✓ update the **firmware**
- ✓ program the **maintenance**
- ✓ manage or customise the **remotes**
- ✓ read **technical manuals** or have a look at the **electrical connections**
- ✓ control the **inputs** and **output** of the control boards
- ✓ **control** the automation with the App

To be used with:



Art.NET-NODE
Cod.677640

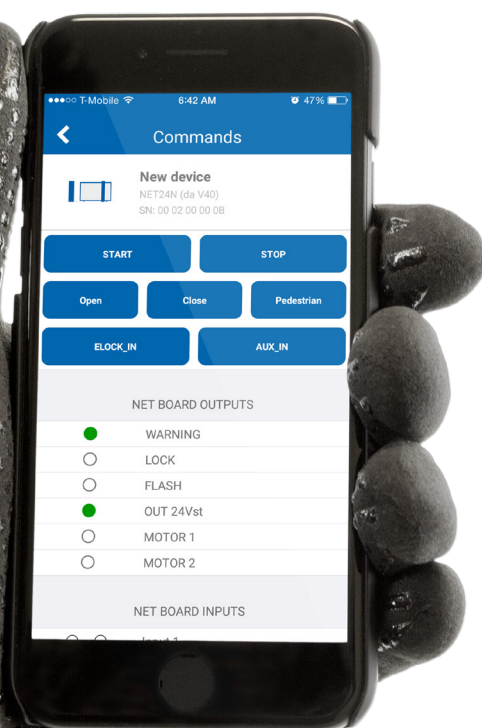

Generic accessories



✓ 24V
✓ 120V
✓ 230V

AURA N

cod. 661130



LINEAR XS

cod. 662080



LINEAR

cod. 662044



COVER/2

cod.681060



LINEAR SHIELD

cod. 662047



PILLY 60 -120

cod. 664000 - 664010



DIGIPRO

cod. 663310



DIGISLIM

cod. 663311



GT-KEY

cod. 663090



DIGIRAD

cod. 663280



BAT

cod. 629290



BLINDOS

cod. 665000



GTI2-GTI4

cod. 672635 - 672645



GTI2M-GTI4M

cod. 672603 - 672613

#safeasyoulike!

Non-copyable remotes!

GTI remotes are multi-function. They have three coding possibilities: DIP SWITCH, Rolling Code and D.A.R.T. the new DEA advanced coding.

You can customise the code of the remotes to guarantee the maximum security to your customer.

D. DEA
A. Advanced
R. Rolling Code
T. Transmission

Looking for **total safety**?
With **NET-BOX** each installer can customise the code of your GTI remotes.



#colourasyoulike!

Choose your favorite colour!

GTI remotes can be customised with button kits in seven colours: green, light green, blue, pink, yellow, orange and purple.



Note: button kits are supplied in packs of 5. The remote must be ordered separately.



NETLINK

is our technology applied to DEA devices for the smart management of your installations, both **locally** and **remotely**.

DE@NET

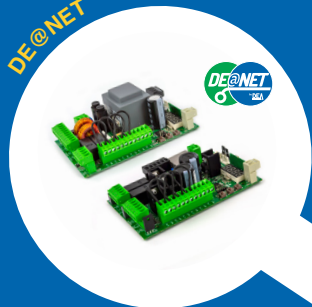

One control board for all our motors, available in 230V and 24V versions.

NET-COM



The device for the managing installations remotely.

NET-NODE



The device for managing installations locally.

NET-BOX



The device for managing remotes from your office.

DEA User & DEA Installer



DEAinstaller:
the App for creating and managing each installation directly from your smartphone.



DEAuser:
the App for opening and closing your DEA gate with just one touch, locally.

Our range

Automations for sliding gates



LIVI N



REV



GULLIVER



Automations for sectional doors



SPACE



ADVANCE



LIVI 902



Automations for swing gates



MAC



STING



LOOK



GEKO



LIVI 502



GHOST 100/200



OLI N



Automations for industrial gates



LATO



550 PL



Barriers



PASS



STOP



TRAFIK



Bollards

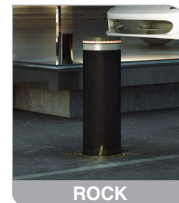

ROCK



HEADQUARTER
DEA SYSTEM S.p.A.
 Via della Tecnica, 6 - 36013 Piovone Rocchette (VI) - ITALY
 ☎ + 39.0445.55.07.89 - 📠 + 39.0445.55.02.65
 info@deasystem.com - www.deasystem.com

Branches > Italia, France, United Kingdom, Ireland, España,
 Portugal, Polska, Deutschland, Беларусь

> **HEAD OFFICE**
DEA GATE AUTOMATION Ltd.
 Sandholes Road - Cookstown - Co. Tyrone
 BT80 9AR - IRELAND
 ☎ + 44 (0)28 8676 6476 - 📠 + 44 (0)28 8676 2414
 info@deagateautomation.com

DEA GATE AUTOMATION Ltd.
 Unit 31 - The IO Centre - Hearle Way - Hatfield - Hertfordshire
 AL10 9EW - UNITED KINGDOM
 ☎ + 44 (0)17.07.24.65.99
 info@deagateautomation.co.uk